

More Information at:



## smart scanning

intelliSCAN® series **scan heads** offer advantages such as expandability and digital servo circuitry, whose powerful algorithms can boost both dynamic performance and marking quality. In addition, the electronics extensively enhances the range of diagnosis possibilities as well as communication between the scan system and the customer's control computer.

SCANLAB can equip its digital servo firmware with multiple control algorithms and parameter sets (tunings). Switching between different algorithms or sets (even during processing) allows scan head dynamics etc. to be reconfigured and thereby optimally adapted to particular task requirements. Application-specific tunings can boost speed and/or positioning accuracy.

intelliSCAN® scan heads allow real-time monitoring of all key operational states of the scan system, such as mirror positions,

mirror speeds, drive currents, supply voltage and temperature. As a result, the scan process can be simulated or – especially in safety-critical applications – monitored, logged and modified if required.

Scan heads of the intelliSCAN® series also create new remote-diagnosis possibilities. They have the necessary facilities to support software-querying of accumulated operating hours, serial number, date-of-manufacture and essential operational states. Thus, deviations can be quickly detected and corrected.

intelliSCAN<sub>de</sub>® is the high-end member of this scan head series. Using galvanometer scanners with digital encoders, the intelliSCAN<sub>de</sub>® features remarkably low drift and dither values, making it ideal for high-end applications.

### Typical Applications:

- Micromachining
- Marking, welding, drilling
- Rapid prototyping, rapid tooling
- Photovoltaic production
- Processing-on-the-fly

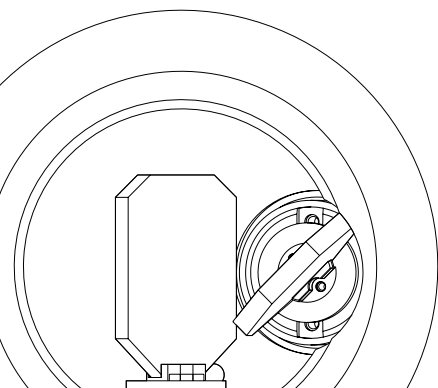

## intelliSCAN<sub>de</sub>® 14 and intelliSCAN® 10, 14

**Dimensions:** same as hurrySCAN® II 10,14

**Weight:** approx. 3 kg (without objective)

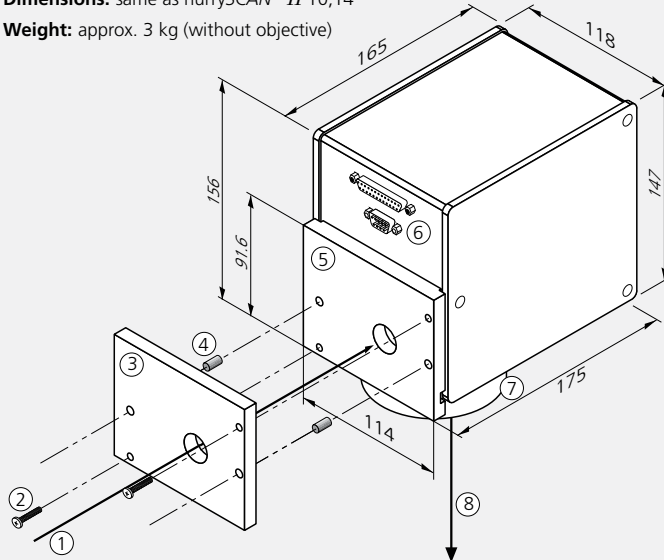

The denoted dimensions refer to **standard housing type** (with standard mounting bracket). Variations in size and form are possible; also housings with water cooling have other dimensions.

## intelliSCAN<sub>de</sub>® 20, 25, 30 and intelliSCAN® 20, 25, 30

**Dimensions:** same as hurrySCAN® 20, 25 and 30

**Weight:** approx. 5.8 kg (without objective)

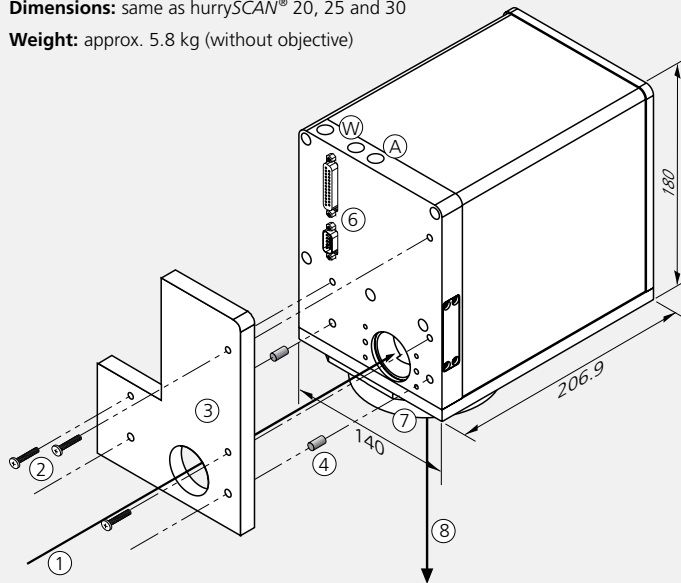

### Legend

- |                                       |                         |                                 |
|---------------------------------------|-------------------------|---------------------------------|
| 1 Beam in                             | 5 Mounting bracket      | A Connection for cooling air    |
| 2 Screws (M6 threads) *               | 6 Electrical connectors | W Connections for cooling water |
| 3 Flange *                            | 7 Objective             |                                 |
| 4 Alignment pins (6 <sub>h6</sub> ) * | 8 Beam out              |                                 |
- (\* not included)

all dimensions in mm

## Housing

The housings of all intelliSCAN® scan heads are identical with those of the hurrySCAN® series.

## Optics

Galvanometer mirrors and objectives with optimized mounts are available for all typical laser types and image fields. Customer-specific configurations are also possible.

## Control

The intelliSCAN® is equipped with a digital standard interface and is easily controlled via SCANLAB's RTC®4 or RTC®5 control board. Scan head diagnosis and all essential configuration parameters are controlled via software commands.

intelliSCAN® scan heads are available with either an SL2-100 interface (20 bits) or an XY2-100 enhanced interface (16 bits, optical also optionally available).

## Options

- Extendable into a three-axis scan system with varioSCAN focusing units
- Also available as a high-performance version with light-weight mirrors (for 14, 20 and 30 mm apertures)
- Various water-cooling implementations for all scan heads either as standard equipment or optionally (for 10 and 14-mm apertures)
- Air cooling for all scan heads either as standard equipment or optionally (for 10 and 14-mm apertures)
- Scan modules without a housing also possible
- Additional reference sensor system (ASC) for automatic self-calibration (not required for intelliSCAN<sub>de</sub>®)
- Application-specific and customer-specific tunings (servo algorithms and parameter sets)
- Camera adapter for process monitoring

### Digital Encoder Technology

intelliSCAN<sub>de</sub><sup>®</sup> scan heads equipped with digital encoder technology are specifically optimized to enhance positioning accuracy without impairing dynamics or mechanical dimensions. This brings maximized dynamic performance and positioning accuracy to application areas needing XY-stage precision and enables applications that demand the highest throughput and accuracy.

Featuring dynAXIS<sub>de</sub><sup>®</sup> galvanometer scanners with digital encoders, intelliSCAN<sub>de</sub><sup>®</sup> scan heads match the high dynamic performance of the industry-proven dynAXIS<sup>®</sup> (with analog position detectors). They enable a positioning resolution of 19-20 bits, exceptionally low dither (electronic noise), best linearity and lowest drift. An SL2-100 interface facilitates comprehensive 20-bit control

via SCANLAB's RTC<sup>®</sup>5 control board. Thanks to the extended resolution, line pitch can be precisely adjusted for applications such as scribing and to eliminate effects such as Moiré patterns.

### Compatibility

Integration of digital encoders does not appreciably change the outer dimensions of the galvanometer scanners. Therefore the housings of all intelliSCAN<sub>de</sub><sup>®</sup> scan heads are identical to those of the hurrySCAN<sup>®</sup> and intelliSCAN<sup>®</sup> series.

Moreover, intelliSCAN<sub>de</sub><sup>®</sup> scan heads are electrically and optically fully compatible with hurrySCAN<sup>®</sup> and intelliSCAN<sup>®</sup> scan heads.

### Quality

The high quality, dependability and industrial ruggedness of SCANLAB's scan solutions are the result of years of experience in the development and manufacture of galvanometer scanners and scan systems. intelliSCAN<sup>®</sup> scan heads have accumulated years of usage deployed in large quantities across industries worldwide. In addition, every individual scan system must first pass the SCAN check burn-in test before it is released for shipment to the customer.

### Example Processing Result

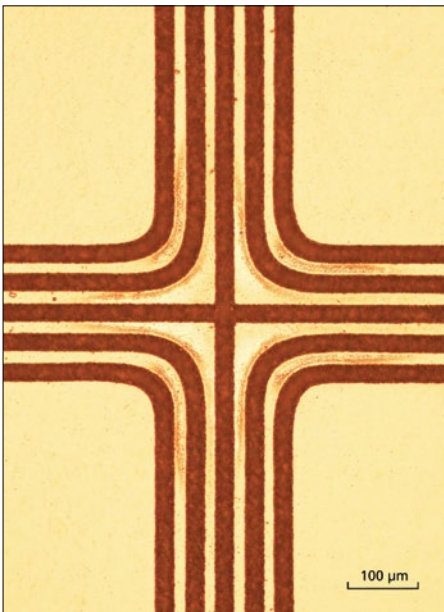

#### Structure parameters

approx. 40 μm line spacing  
approx. 60 μm and 90 μm corner radii

#### System

intelliSCAN<sub>de</sub><sup>®</sup> 14  
f = 170 mm objective

#### Process parameters

sharp edge tuning  
2 m/s marking speed  
5 m/s positioning speed  
0.10 ms tracking error

#### Results

smooth corners with small corner radii  
(low tracking error)  
excellent line straightness (low dither)

## Dynamic Specifications

(all angles are in optical degrees)

Aperture [mm]	intelliSCAN <sup>®</sup> / intelliSCAN <sub>de</sub> <sup>®</sup>				
	10 <sup>(1)</sup>	14	20	25	30
<b>Fast Vector tuning</b>					
<b>Typical speed<sup>(2)</sup></b>					
Marking speed	3.0 m/s	1.5 m/s	1.0 m/s	0.8 m/s	0.7 m/s
Positioning speed	14.0 m/s	12.0 m/s	11.0 m/s	10.0 m/s	9.0 m/s
<b>Writing speed</b>					
Good writing quality	1150 cps	500 cps	340 cps	260 cps	220 cps
High writing quality	800 cps	340 cps	230 cps	170 cps	150 cps
<b>Dynamic performance</b>					
Tracking error	0.12 ms	0.21 ms	0.32 ms	0.50 ms	0.55 ms
<b>Step response time<sup>(3)</sup></b>					
1% of full scale	0.4 ms	0.45 ms	0.70 ms	1.0 ms	1.1 ms
<b>Step tuning</b>					
<b>Step response time<sup>(3)</sup></b>					
10% of full scale	1.0 ms	1.4 ms	1.9 ms	2.7 ms	3.5 ms
100% of full scale	3.0 ms	3.7 ms	5.3 ms	8.0 ms	11.0 ms

<sup>(1)</sup> currently not available as intelliSCAN<sub>de</sub><sup>®</sup>

<sup>(2)</sup> with F-Theta objective, f = 160 mm (f = 163 mm for intelliSCAN<sup>®</sup> 20, 25 and 30)

<sup>(3)</sup> settling to 1/1000 of full scale

## Precision Specifications

(all angles are in optical degrees)

	intelliSCAN <sub>de</sub> <sup>®</sup> digital encoder	intelliSCAN <sup>®</sup> analog detector
<b>Angle measurement</b>		
<b>Repeatability (RMS)</b>	< 0.4 μrad	< 2 μrad
<b>Positioning resolution (with SL2-100)</b>	0.82 μrad <sup>(4)</sup>	3.2 μrad
<b>Dither (position noise, RMS)</b>	< 1.6 μrad	< 5 μrad <sup>(5)</sup>
<b>Temperature drift</b>		
Offset	< 15 μrad/K	
Gain	< 8 ppm/K	
<b>8-h-drift (after 30 min warm-up)<sup>(6)</sup></b>		< 0.6 mrad
Offset	< 20 μrad	
Gain	< 20 ppm	
<b>24-h-drift (after 3 h warm-up)<sup>(6)</sup></b>		
Offset	< 12 μrad	
Gain	< 25 ppm	
<b>Nonlinearity</b>	< 0.5 mrad / 44°	< 3.5 mrad / 44°

<sup>(4)</sup> for intelliSCAN<sub>de</sub><sup>®</sup> 20; intelliSCAN<sub>de</sub><sup>®</sup> 14: 1.3 μrad

<sup>(5)</sup> for micromachining tuning

<sup>(6)</sup> at constant ambient temperature and load, without water cooling; achievable even under varying load when equipped with temperature-controlled water cooling

## Common Specifications

(all angles are in optical degrees)

<b>Optical performance</b>	
Typical scan angle	±0.35 rad <sup>(7)</sup>
Gain error	< 5 mrad
Zero offset	< 5 mrad
<b>Power requirements</b>	
	30 V DC, max. 6 A <sup>(8)</sup> or 48 V DC, max. 6 A <sup>(8)</sup>
<b>Interface</b>	
	XY2-100 Enhanced, SL2-100 or optical data transfer
<b>Operating temperature</b>	
	25 °C ± 10 °C
<b>Typical air requirements<sup>(9)</sup></b>	
	clean, filtered air 20 l/min at Δp < 2 bar
<b>Typical water requirements<sup>(9)</sup></b>	
	5 l/min at Δp < 0.1 bar, p < 4 bar
<b>Weight and dimensions</b>	
	see illustration

<sup>(7)</sup> for intelliSCAN<sup>®</sup> 25: ±0.26 rad (scanner 1), ±0.40 rad (scanner 2)

<sup>(8)</sup> max. 3A with intelliSCAN<sup>®</sup> 10, 14

<sup>(9)</sup> standard for intelliSCAN<sup>®</sup> and intelliSCAN<sub>de</sub><sup>®</sup> 20, 25, 30; optional for intelliSCAN<sup>®</sup> 10 and 14 and intelliSCAN<sub>de</sub><sup>®</sup> 14

## Some of the available application-optimized tunings:

Tuning	Optimized for	Application
Fast vector tuning	balanced optimum of all parameters in a wide range of applications	vector marking
Step tuning	minimal step response time	drilling
Sharp edge tuning	low acceleration time, small edge rounding	micro structures
Micromachining tuning	low dither, low line waviness	vector marking, micro structures
Micromachining-sharp edge tuning	low acceleration time, low dither	micro structures
Line scan tuning	highest marking speed (limitation: higher acceleration time)	ultrashort pulse laser processing