

ULTRAFAST LASER

► Ultra-stable Picosecond Fiber Laser

Industrial grade ultra fast laser seed source excellent solution

The ultra-stable picosecond fiber laser offered by Precilasers is an excellent seed source for industrial-grade ultrafast laser applications. It has the advantages of fiber lasers: small size, no need for thermal management, and good beam quality. The central wavelength of the ultrafast fiber laser is 1064 nm and the repetition rate can be from 20 to 30 MHz. The temporal pulse width can be less than 10 ps and the spectral width is less than 0.5 nm. The maximum pulse energy can be up to 400 nJ. By utilizing a unique nonlinear technology to achieve mode locking, the ultrashort pulse not only has good long term stability, but also can withstand 0-45 °C operating environment. The laser also has excellent performance on self-starting of mode-locking, which can achieve more than 100,000 consecutive self-starts, and most of the startup time is less than 2 s.

Key Features:

- Narrow pulse width, narrow spectrum (<0.5 nm)
- Ultrafast imaging
- Excellent beam quality
- Linear polarization
- Good power stability, Applications

Applications:

- High power ultrafast laser seed source
- Super fast imaging
- Precision measurement
- Optical frequency comb

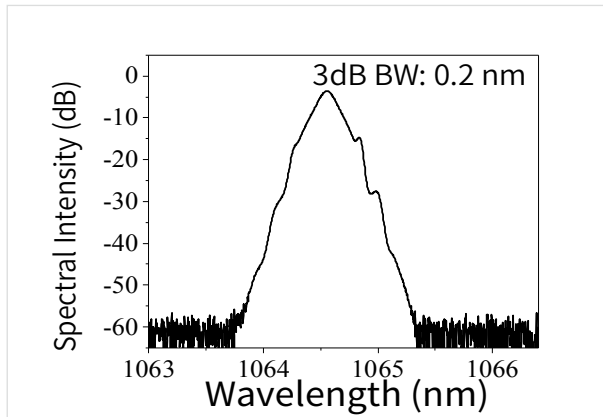

Typical output spectrum

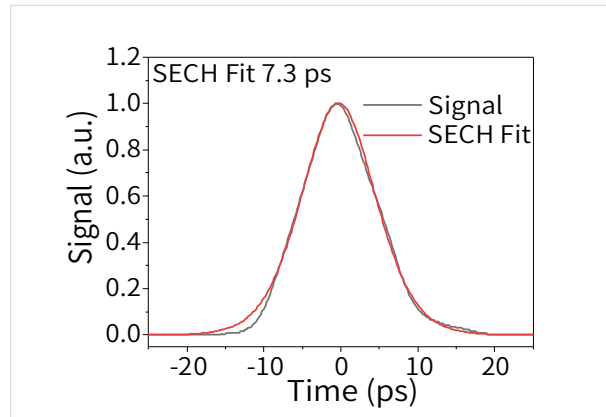

Typical autocorrelation trace of the ultrafast laser.



FL-PS-1064-8/12-X



FL-PS-1064-12-X

► Ultra-stable Picosecond Fiber Laser

Industrial grade ultra fast laser seed source excellent solution

Model	FL-PS-1064-8-X	FL-PS-1064-12-X	FL-PS-1064-12-XX
Central Wavelength , nm	1064 nm		
Pulse Width , ps	~8	~12	~12
Pulse Energy , nJ	0.3-3	0.3-3	Maximum 400
Average Power , mW	6-60	6-60	Maximum 10000
Maximum Peak Pulse Power , W	350	250	Maximum 30000
Spectral Width , nm	<0.5	<0.5	<5
Repetition Frequency , MHz	20-30(Pulse picker is optional)	20-30(Pulse picker is optional)	20-30(Pulse picker is optional)
Polarization	linear polarization , > 100: 1	linear polarization , > 100: 1	linear polarization , > 100: 1
Power Stability	<1% RMS@3hrs	<1% RMS@3hrs	<1% RMS@3hrs
Beam Quality	$M^2 < 1.1$, TEM ₀₀	$M^2 < 1.1$, TEM ₀₀	$M^2 < 1.2$, TEM ₀₀
Output Connector	Fiber Patchcord or Collimator	Fiber Patchcord or Collimator	Fiber Patchcord or Collimator
Dimension	225×120×40 mm without pulse picker 220×142×45 mm with pulse picker	225×120×40 mm without pulse picker 220×142×45 mm with pulse picker	483×423×133 mm
Power Supply	12V DC/1A	12V DC/1A	220 V AC

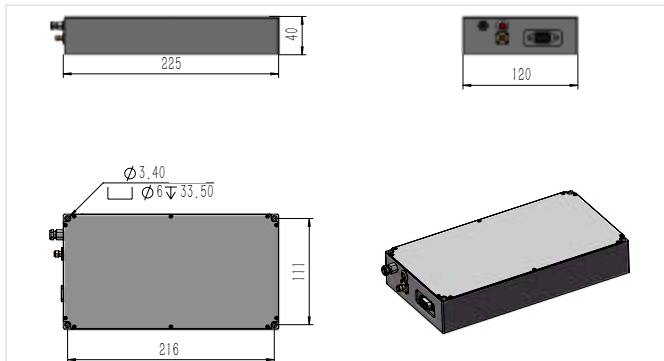

Size for FL-PS-1064-8/12-X without pulse picker

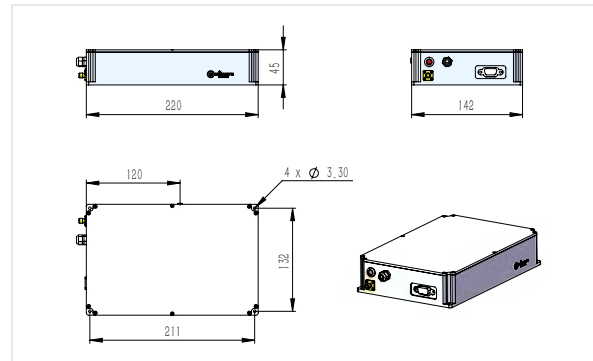

Size for FL-PS-1064-8/12-X with pulse picker

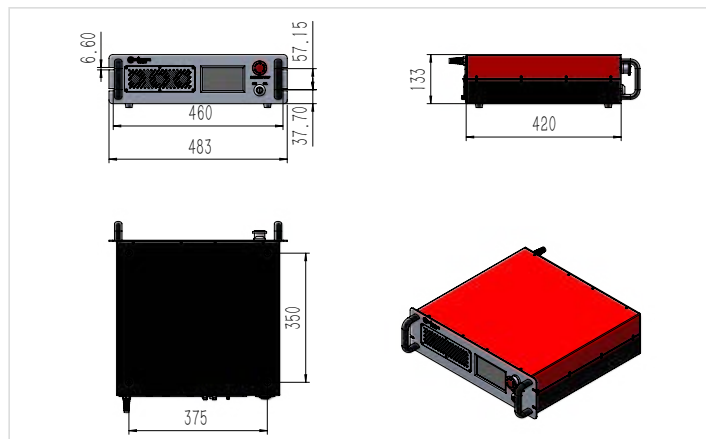

Size for FL-PS-1064-12-XX